



EKOS - EKOSTONE

PROFESYONEL DETAYLAR



YAĞ GÖSTERGELİ ŞANZIMAN

Riduttore con livello olio esterno
Getriebe mit externem Ölstand
Caja de cambios con nivel de aceite externo
Boîte de vitesses avec niveau d'huile externe

HİDROLİK HORTUM TUTUCULAR

Porta tubi idraulici
Hydraulikrohrhalter
soporte de tubos hidráulicos
support de tubes hydrauliques

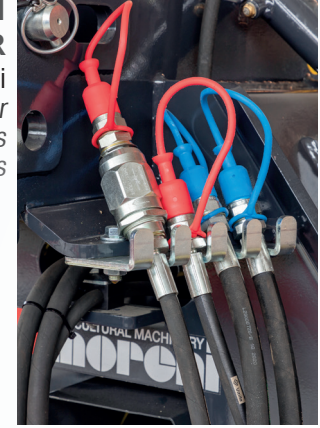

LED TRAFİK KİTİ

Luci a LED LED Lichter
Luces LED
Lumières LED



12 MM GÜÇLENDİRİLMİŞ ŞASI

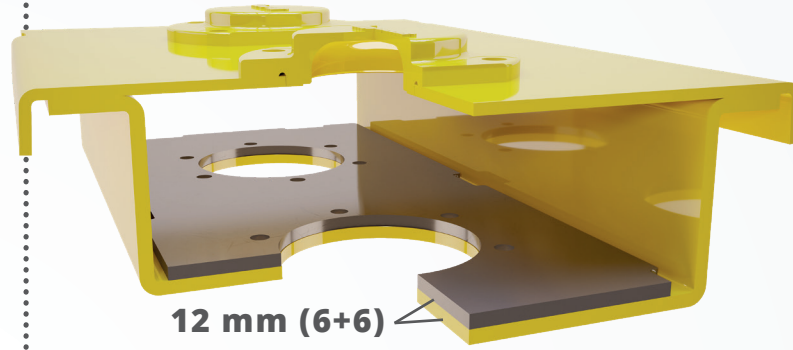

Cassa rinforzata a 12 mm
12 mm verstärktes Chassis
Chasis reforzado de 12 mm
Châssis renforcé de 12 mm

ŞOK OBSÖRVASYONLU TESVİYE BARI

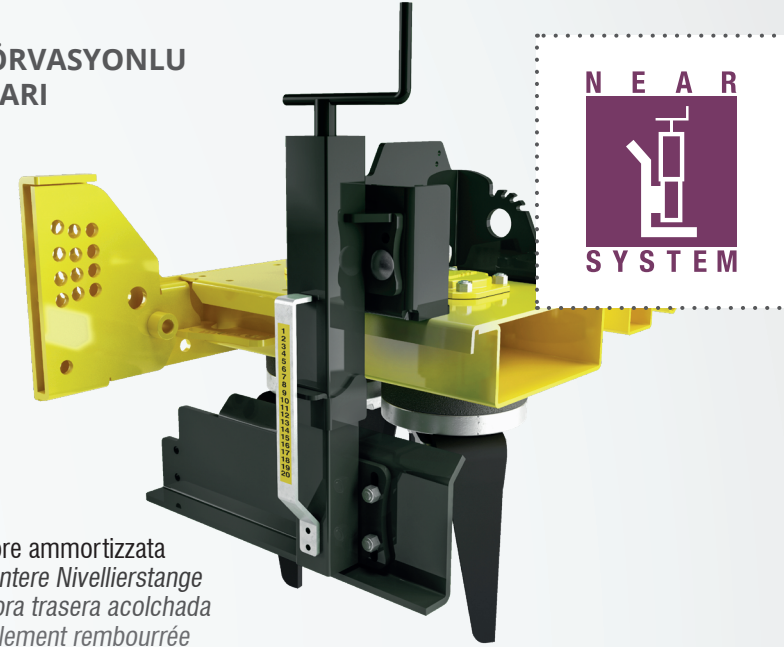

Barra posteriore ammortizzata
Gedämpfte Hintere Nivellierstange
Barra niveladora trasera acolchada
Barre de nivellement rembourrée



SİGORTA PİMLİ TRAKTÖR İZ KABARTICI

Rompitraccia con bullone di trancio
Spurbrecher mit Bolzensicherung
Erradicadores de marcas de ruedas con seguridad de perno
Effaceurs de traces de roues avec sécurité de boulon

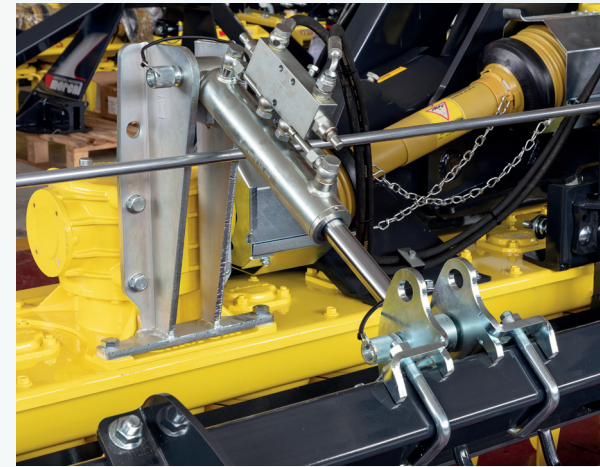

HİDROLİK MERDANE DERİNLİK AYARI

Registro rullo idraulico disponibile
Einstellung der hydraulischen Walze verfügbar
Ajuste del rodillo hidráulico disponible
Réglage hydraulique des rouleaux disponible

STANDART ÖZELLİKLER



KALINLAŞTIRILMIŞ



ROTORLAR

ROTORLAR ARASI DAR MESAFE

Interasse ridotto dei rotori

Reduzierter Zwischenraum der Rotoren

Espacio reducido de los rotors

Réduction de l'espace entre les rotors

ÇALIŞMA
GENİŞLİĞİ MORENİ RAKİPLER

3.000	14	10 - 12
3.500	16	12 - 14
4.000	18	14 - 16
4.500	20	16 - 18
5.000	22	18 - 20

ROTOR SAYISI

DİŞLİ

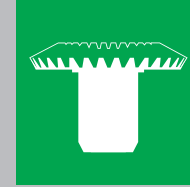

SİSTEMİ

MERKEZ ŞAFT İÇİN TEK PARÇA DİŞLİ SİSTEMİ

Corona allungata per proteggere l'albero centrale

Verlängerte Krone zum Schutz der Zentralwelle

Corona alargada para proteger el eje central

Couronne allongée pour protéger la tige centrale

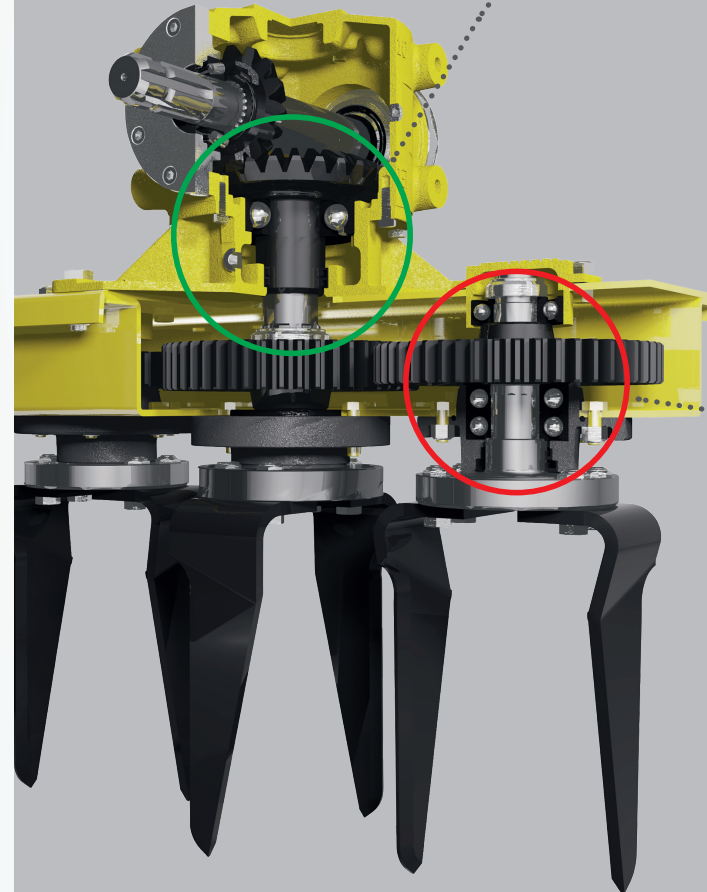

ÇİFT BİLYALI

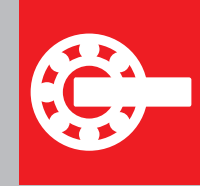

Y A P I

3 BİLYALI ROTOR YAPISI

3 cuscinetti per rotore

3 Lager pro Rotor

3 rodamientos cada rotor

3 roulements chaque rotor

ROTOR ÇEŞİTLERİ

EKOS

ÇİFT BIÇAKLI STANDART ROTOR

Rotore a 2 lame classico
Standard Rotor mit 2 Klingen
Rotor estándar de 2 cuchillas
Rotor standard à 2 lames

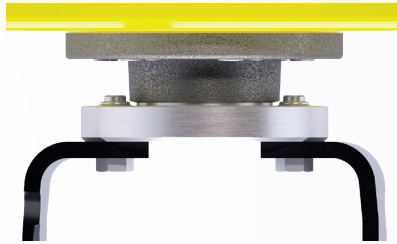

TAŞ KORUMA



SİSTEMİ

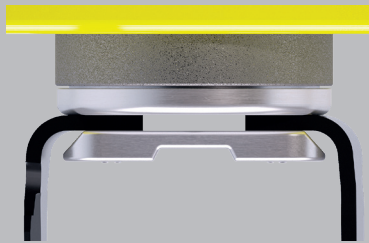

EKOSTONE

TAŞ KORUMALI ROTORLAR

Rotore antisasso
Steingeschützter Rotor
Rotor protegido contra piedras
Rotor protégé contre les pierres

KOLAY DEĞİŞTİRİLEBİLİR



SİSTEM EKOS Q

HIZLI DEĞİŞTİRİLEBİLİR BIÇAKLAR

Sgancio rapido delle lame
Schnellauslöser der Klingen
Liberación rápida de las cuchillas
Libération rapide des lames



TAŞ KORUMA



SİSTEMİ



KOLAY DEĞİŞTİRİLEBİLİR



SİSTEM

EKOSTONE Q

TAŞ KORUMALI ROTORLAR

Rotore antisasso
Steingeschützter Rotor
Rotor protegido contra piedras
Rotor protégé contre les pierres

HIZLI DEĞİŞTİRİLEBİLİR BIÇAKLAR

Sgancio rapido delle lame
Schnellauslöser der Klingen
Liberación rápida de las cuchillas
Libération rapide des lames

ÜÇLÜ BIÇAK



SİSTEMİ

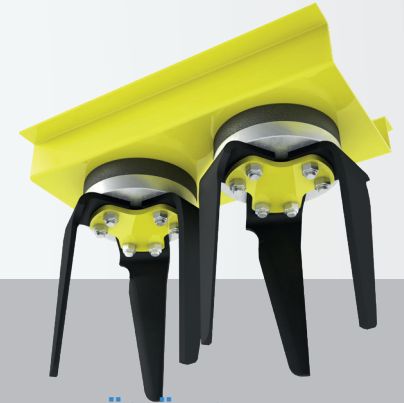

TAŞ KORUMA



SİSTEMİ



ÜÇLÜ BIÇAK



SİSTEMİ

EKOSTONE 3D

TAŞ KORUMALI ROTORLAR

Rotore antisasso
Steingeschützter Rotor
Rotor protegido contra piedras
Rotor protégé contre les pierres

HER ROTORDA 3'LÜ BIÇAK

3 Lame per rotore 3
Blätter pro Rotor 3
Cuchillas cada rotor 3
lames chaque rotor

KATLANIR ŞASI

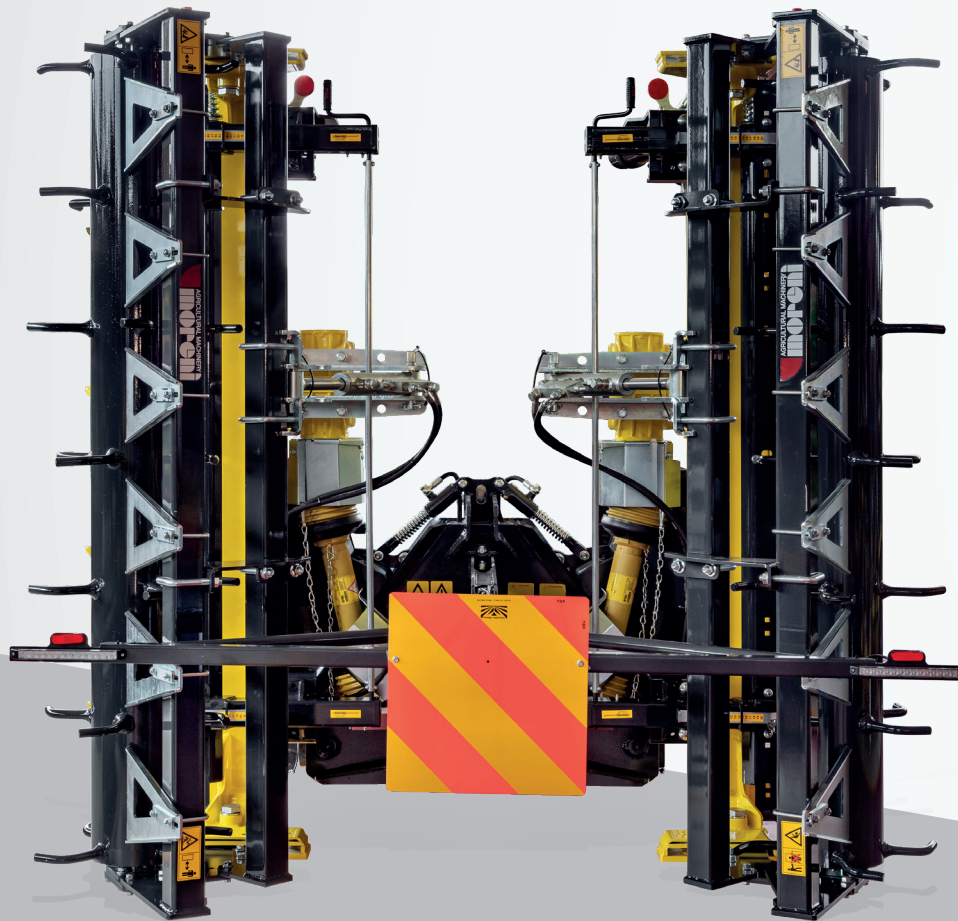

2.297 mm

ŞANZIMANLARIN KESIŞİM YERİNDEKİ ROTORLARIN DİZİLİMİ

I rotori all'intersezione delle due trasmissioni si incrociano tra loro
Die Rotoren am Schnittpunkt der beiden Getriebe kreuzen sich
Los rotores en la intersección de las dos transmisiones se cruzan
Les rotors à l'intersection des deux transmissions se croisent



MERDANELER

BORU
MIRDANE

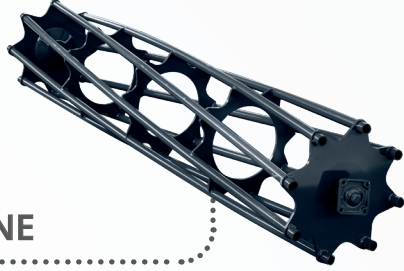

ÇİZEL
MIRDANE



PARÇALAYI
CILI MIRDANE

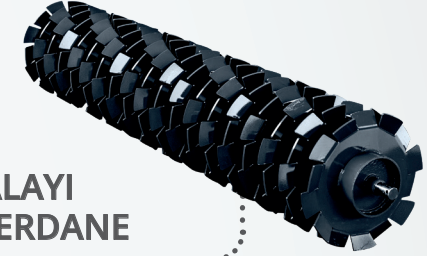

ÇİVİLİ
MIRDANE

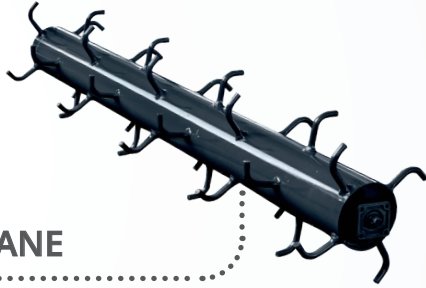

KAFES
MIRDANE

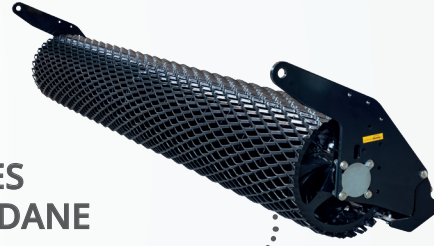

TRAPEZ
MIRDANE



DÜZ BORU
MIRDANE

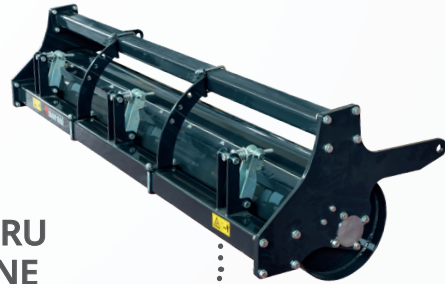

SİRAL
MIRDANE

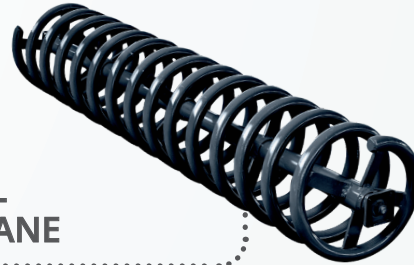

SAMURAI BİÇAKLAR



TUNGSTEN
KAPLAMALI
BİÇAKLAR



EKOS

3.000		3.365		2.297	14	1' 3/4" Z=6	1000/338	300	90 - 210	1621	1717	1851	1761	1824	1836	1723										
3.500		3.805															16	300	100 - 210	1728	1836	1987	1883	1955	1970	1864
4.000		4.245															18	300	110 - 210	1833	1953	2122	2003	2085	2102	2003
4.500		4.685															20	300	130 - 210	1942	2074	2261	2127	2218	2238	2123
5.000		5.125															22	300	150 - 210	2071	2211	2415	2271	2371	2392	2259

EKOSTONE

3.000		3.365		2.297	14	1' 3/4" Z=6	1000/338	300	90 - 230	1743	1838	1973	1883	1946	1958	1845										
3.500		3.805															16	300	100 - 230	1867	1975	2127	2022	2094	2109	2003
4.000		4.245															18	300	110 - 230	1990	2110	2279	2160	2242	2259	2160
4.500		4.685															20	300	130 - 230	2117	2249	2435	2302	2392	2413	2298
5.000		5.125															22	300	150 - 230	2255	2395	2599	2455	2555	2576	2443



Via Eugenio Montale, 35 - 25018 Montichiari (BS) ITALY - Tel +39 030 9960215 - Fax +39 030 9961299 - www.moreni.it - info@moreni.it

